

Cybortronics Inc.

Model HR2050 Chamber



Operation And Maintenance Manual



CONFORMS TO
UL STD 61010A-1
CERT. TO CAN/CSA
C22.2 STD NO.1010.1

PUBLISHED BY:

Cybortronics Inc.
13845-C Alton Parkway
Irvine, CA 92618

Phone: 1-800-289-8203

1-949-855-2814

FAX: 1-949-855-0278

E-Mail: www.sales@cybortronics.com

No part of this manual may be reproduced in any form or by any means, electronic or mechanical (including photocopying), nor may its contents be communicated to a third party without prior written permission by Cybortronics Inc.

Contents of this manual may change without notice.



Revision Date: January 9, 2004

Table of Contents

		Page
SECTION 1	General Information	
	Safety	4
	Warranty	5
	Packing List	6
SECTION 2	Product theory of Operation	7
	Specifications, Dimensions and pictorials	9
	Watlow Quick programming Guide	16
SECTION 3	Installation	
	Electrical Requirements	17
	Wiring Requirements	
	Electrical Connections	
SECTION 4	Set Up	18
	initial Turn-On	
	Verification of Controller	19
	Verification of Chamber Functions	
	Dehumidifier Functions	
SECTION 5	Calibration	20
SECTION 6	Maintenance	21
SECTION 7	Replacement Parts	24
SECTION 8	Schematics, Drawings	27

Chapter 1

GENERAL INFORMATION

Safety

Throughout this manual there are important instructions regarding the safety considerations. They are focused as follows:



WARNING Warning denotes a hazard. It calls attention to a procedure, practice, condition or situation, which if not correctly performed or adhered to, could result in injury to, or death of personnel.



CAUTION Caution denotes a hazard. It calls attention to a procedure, practice, condition or situation, which if not correctly performed or adhered to, could result in damage to or destruction of part or all of the product.



CAUTION Note highlights important information. It calls attention to an essential procedure, practice, or observation.



Indicates an Electrical Hazard. Improper handling could cause electrical shock resulting in serious injury or death.

Warranty

- Cybortronics issues a warranty for this product for the material and parts for one, (1) year from the date of shipment.
- Cybortronics issues a warranty for labor costs for ninety, (90) days from date of shipment.
- Cybortronics issues the same warranty for product shipped overseas, **ONLY** if a Cybortronics certified service representative witnesses the unpacking, and installation of the product.
- Additional warranties, and service contracts are available. Call Cybortronics Inc. and we will be happy to assist to your service needs.

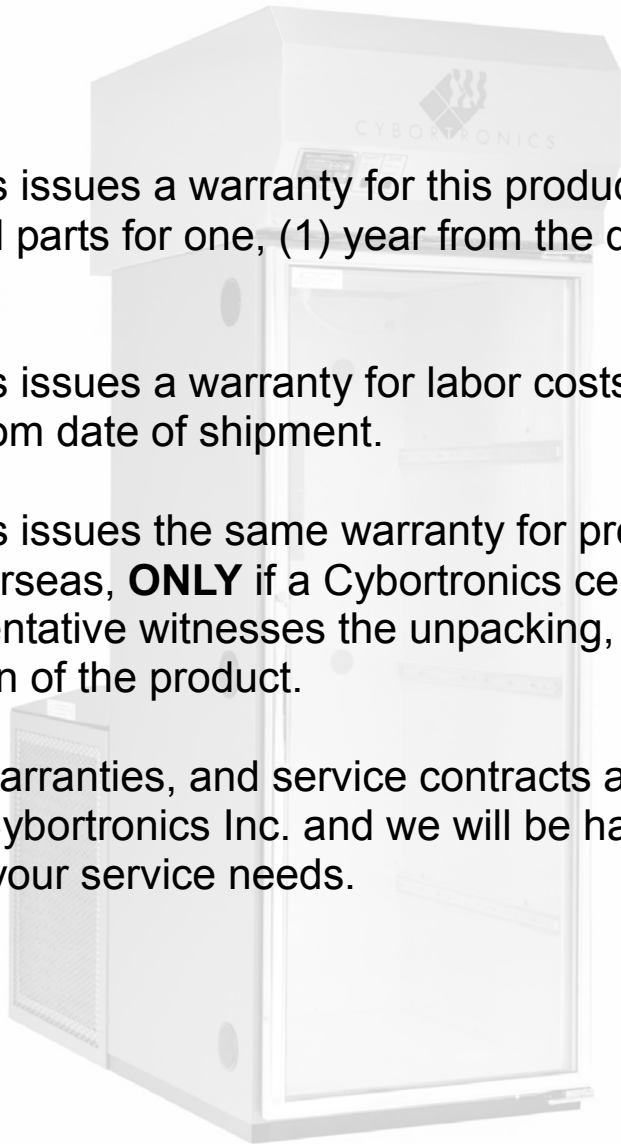

PACKING LIST

Your Cybortronics Inc. Model HR2050 Chamber, (standard model) has been shipped from the factory with the following items. Please take an inventory of these items.

Contact Cybortronics Inc. if any items are missing.

NOTE: Your chamber may have additional items, please refer to your purchase order.

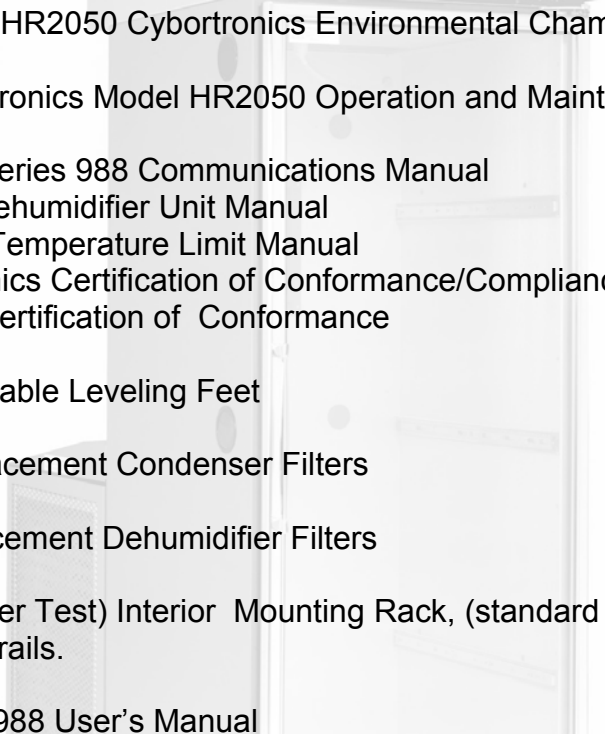
1. One, (1) Model HR2050 Cybortronics Environmental Chamber
 2. One, (1) Cybortronics Model HR2050 Operation and Maintenance Manual
Consisting of:
 - a. Watlow Series 988 Communications Manual
 - b. Muntz Dehumidifier Unit Manual
 - c. Series L Temperature Limit Manual
 - d. Cybortronics Certification of Conformance/Compliance
 - e. Watlow Certification of Conformance
 3. Four, (4) Adjustable Leveling Feet
 4. Three (3) Replacement Condenser Filters
 5. Two, (2) Replacement Dehumidifier Filters
 6. UUT, (Unit Under Test) Interior Mounting Rack, (standard 19 inch rack rails with 6 support shelf rails).
 7. Watlow Series 988 User's Manual
- 

SECTION 2 PRODUCT THEORY OF OPERATION AND SPECIFICATIONS

THEORY OF OPERATION

The HR2050 temperature chamber provides an environment in which electronic manufactured product (unit under test, UUT) can be subjected to operating temperatures inside and outside normal operating environments. The temperature chamber takes on the form of a standard electronic equipment cabinet and features a standard 19" rack rail system to best adapt to the UUT. A process controller monitors the air in the chamber and controls the functions of air circulation, heating, cooling, dehumidification, and UUT power control, to induce and regulate the environment.

BLOWER

High rate air flow is induced through the use of a 1300 CFM ¾ hp blower that is designed to circulate the air over the UUT and through the temperature-inducing components of the chamber, for rapid and efficient transfer of temperatures to and from the UUT.

HEATER

A triple element resistive heater of 14 kilowatts is proportionally controlled through solid-state relays to induce and maintain temperatures rises from -10C to 80 C.

REFRIGERATION

A 3.5 hp R507 based refrigeration system is used to remove the heat from the chamber and to provide temperatures as low as -10C. The refrigeration system throttles condensed liquid refrigerant to the evaporator (the cold component in the refrigeration system) by the temperature controller through the use of a pulsing solenoid valve. This enables the cooling volume or intensity to be proportionally delivered to the chamber and UUT.

DEHUMIDIFIER

A desiccant based dehumidifier re-circulates the interior air in the chamber through a regenerative rotating desiccant wheel to remove moisture from the

interior air and to minimize condensation on the UUT during temperature rises from freezing.

CONTROLLER

The components of the chamber are controlled via a Watlow 981 process controller that samples the interior air temperature and regulates the heating, cooling and dehumidification functions for ramp to, and maintain desired test temperatures within the chamber. The 981 will operate manually through inputs from the front panel keypad, from programmed ramp and soak profiles stored in memory, or through instructions received via it's standard RS232 communication port.

A separate and independent Watlow Series L over-temperature controller monitors the air inside the chamber for conditions above 80C. The controller then inhibits the UUT power, heating and cooling functions and sounds an Sonalert alarm in the event these conditions exist. This alarm condition requires a manual reset by the operator to return the system to normal function.

- **Temperature range of -10°C to 80°C**
- **Temperature rate of change of 5°C per minute with no live load and 50 lbs. of Fixtured Product**
- **50,000 BTU Refrigeration System**
 - **Self contained within the chamber.**
 - **R-507 Ozone Safe Refrigerant**
 - **Compressor Inhibit if Refrigerant lost**
- **40,000 BTU Heating System**
- **1500 CFM Air Recirculation with "Vertical Airflow" design**
- **Watlow Model 981 Temperature Controller**
 - **20 step Ramp & Soak profiling**
 - **RS-232 , RS-422, or EIA 485 Communications Interface**
- **Safety Alarms with LED Display and Audible alert**
 - **Over-Temperature**
 - **Blower Failure**
 - **Input power phase status**
- **Front Panel Display and Control of Alarm Status and UUT Power Control**
- **Double Pane Glass Doors for product visibility**
- **Brushed Stainless Steel and Granite Grey Powder-Coat Exterior**
- **AC Power requirements, 208 VAC, 3 Phase, 60 Amps (w/UUT fully loaded)**

HR2050 Chamber Dimensions Front View

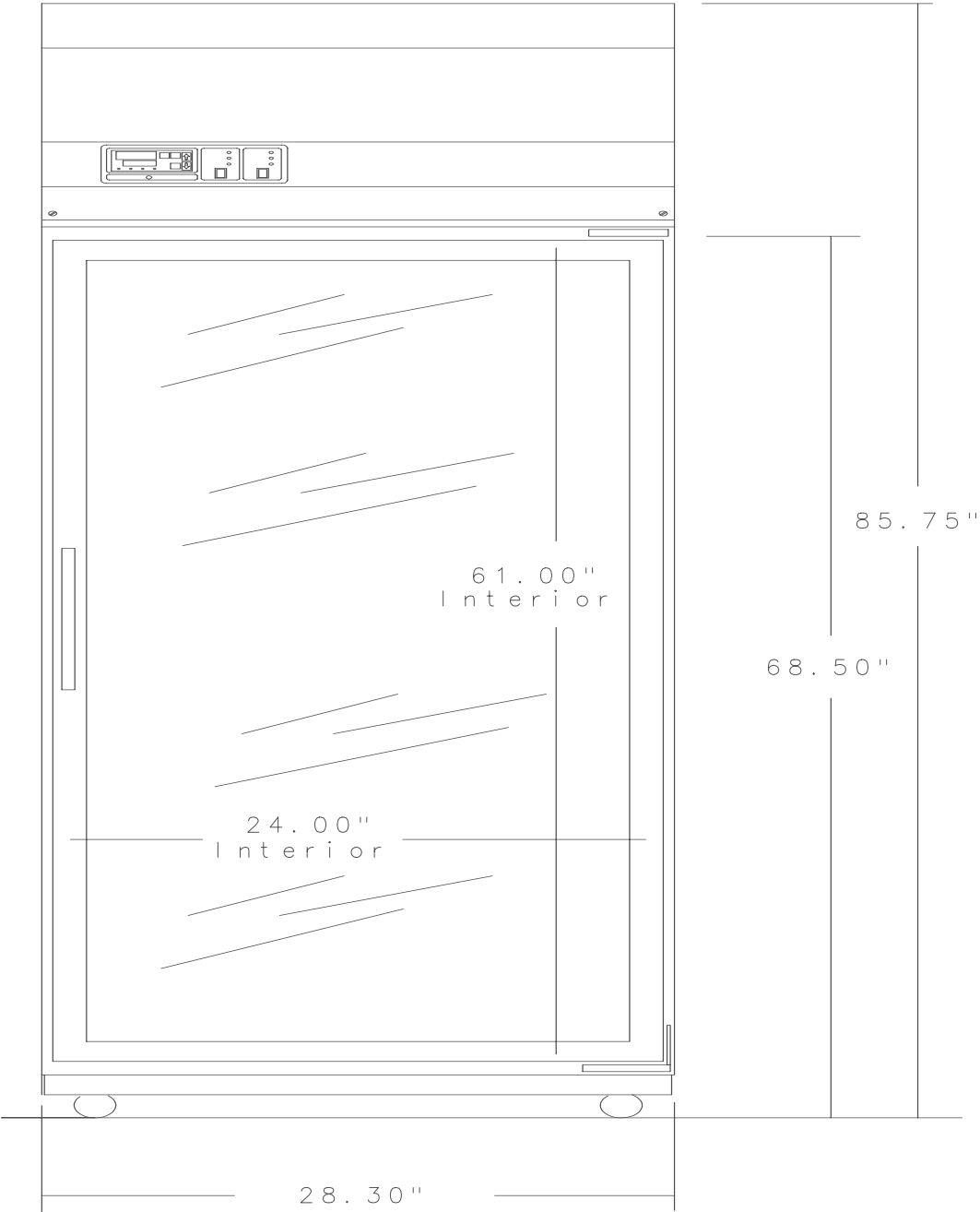

HR2050 Chamber Front View



HR2050 Chamber Rear View

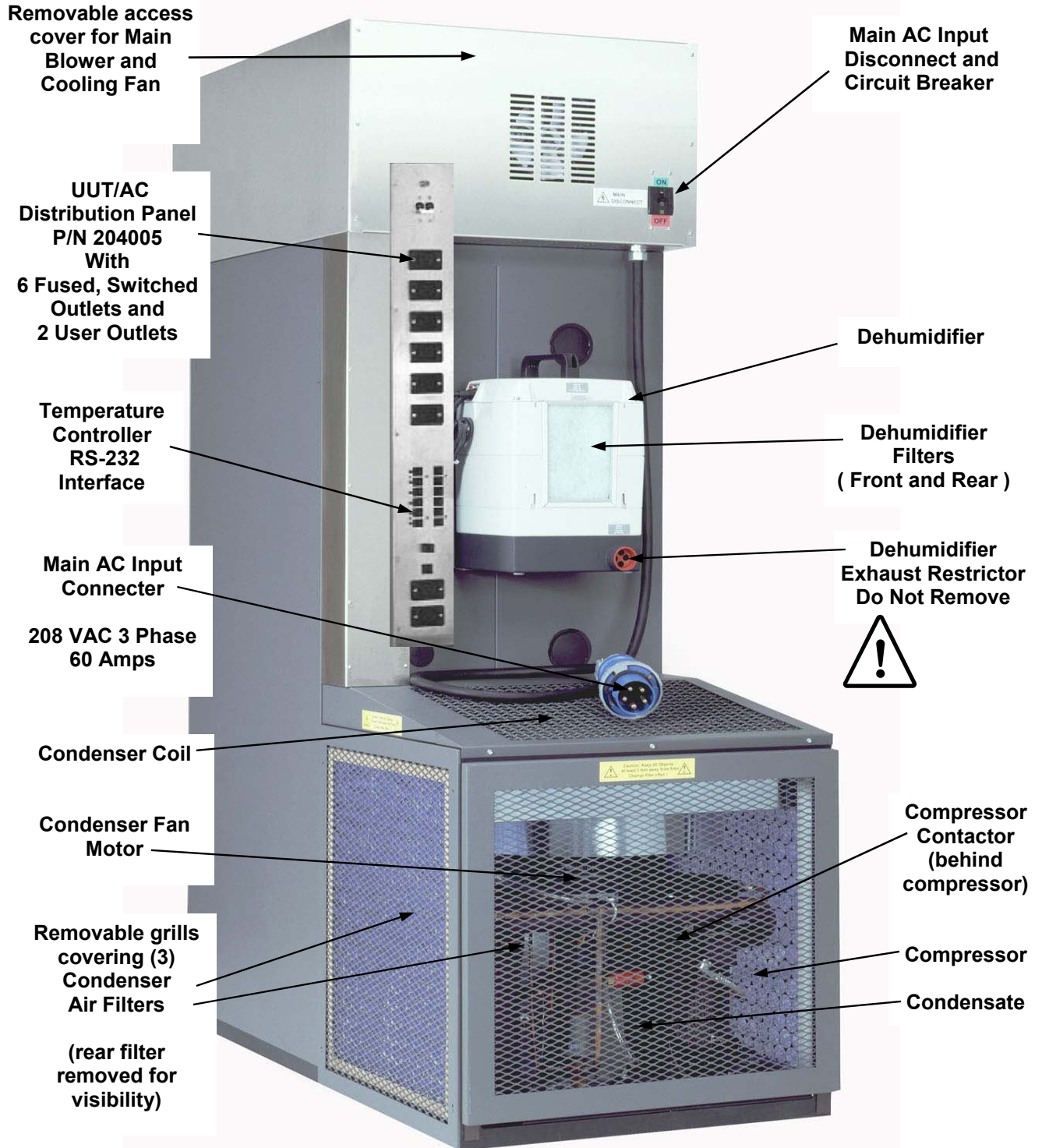

HR2050 Chamber Dimensions Footprint

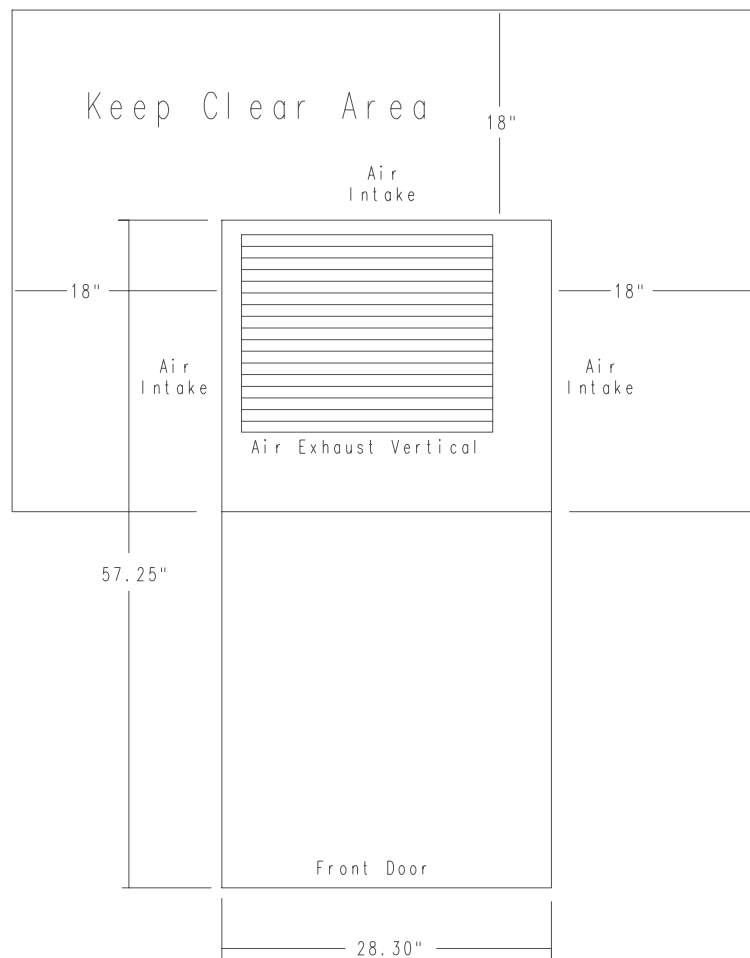

CHAMBER CONTROL PANEL

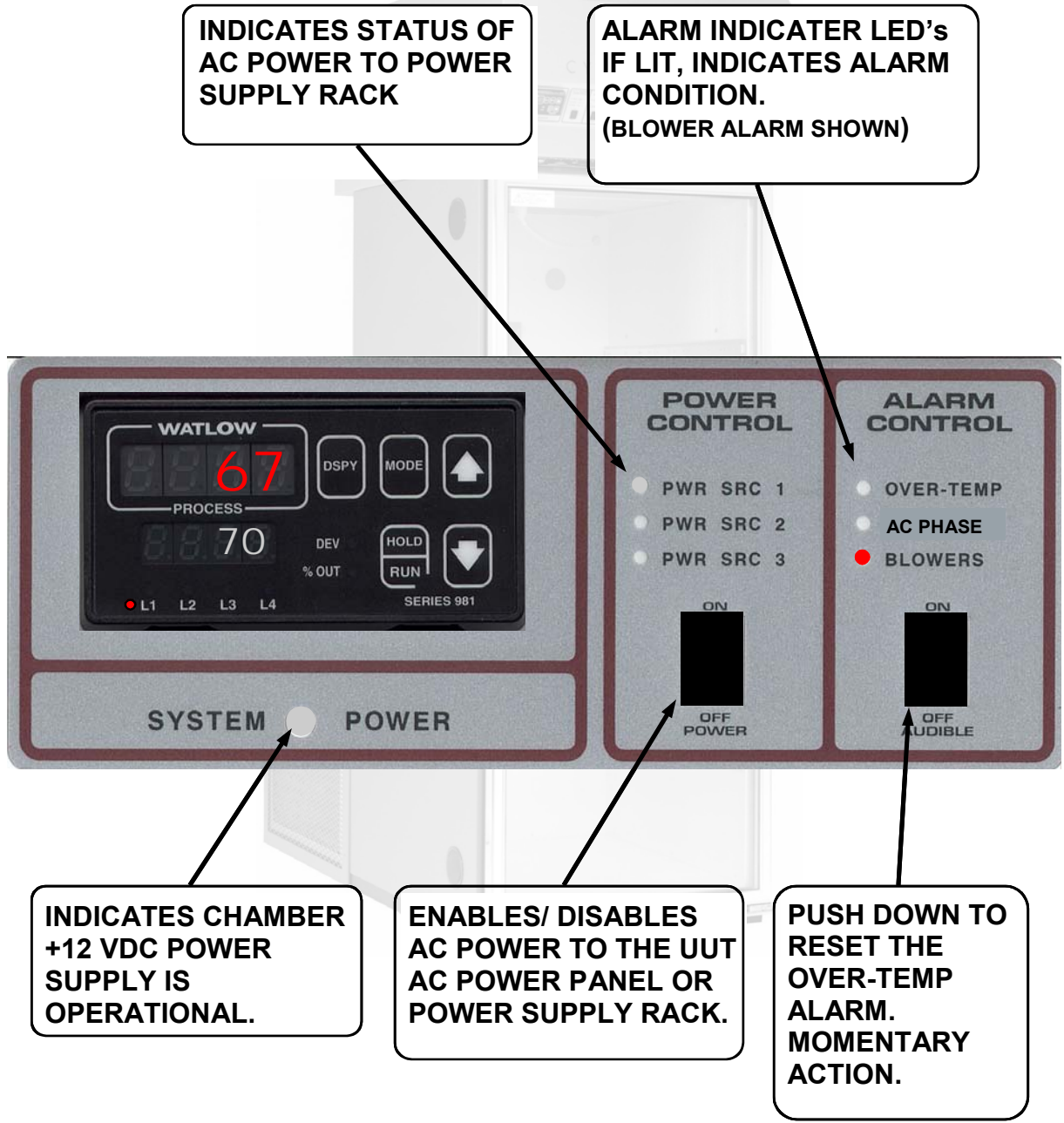

HR2050 Chamber Dimensions Side View

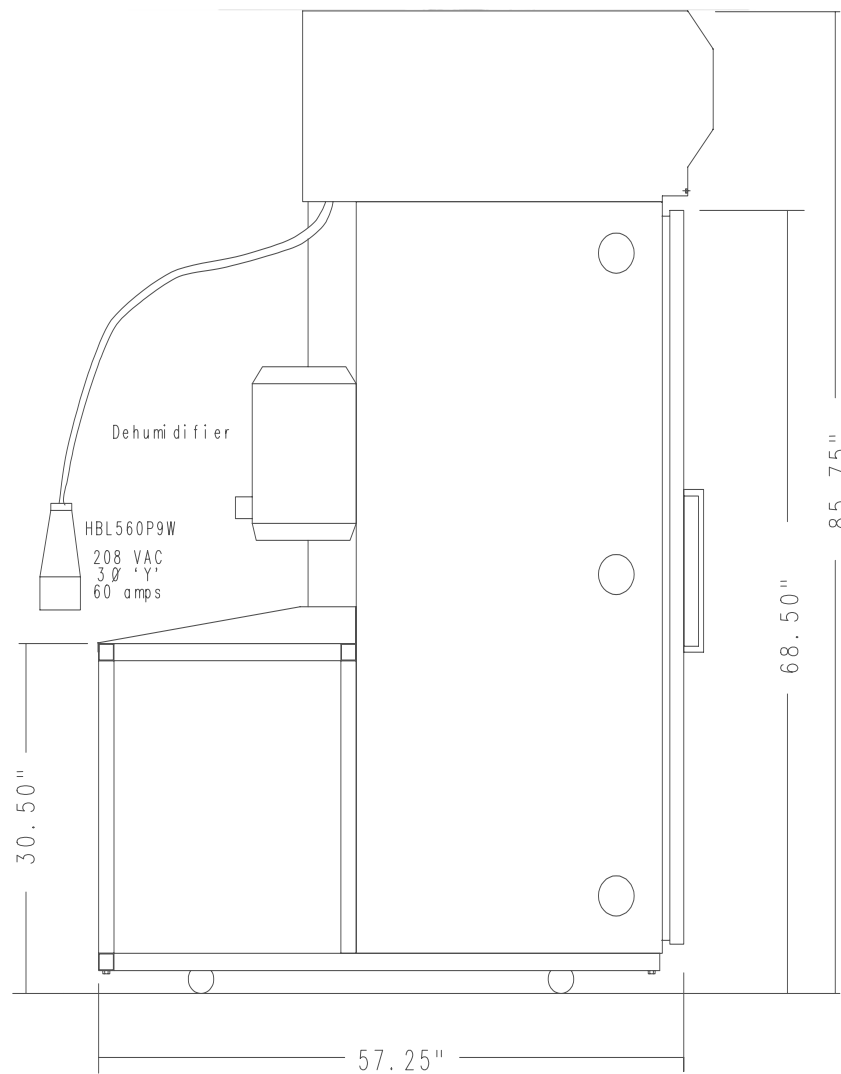

CYB20477 AC Distribution Panel

The CYB20477 AC Distribution Panel is an option available in both 115 VAC and 208 VAC single phase versions. This panel provides six (6) fused Switched Outlets. The 6 Switched Outlets are controlled by individual Solid State Relays. Each of these SSR's are turned on or off by a connection to the DTR signal line on the RJ-45 interfaces located below the outlets. Two RJ-45's are provided for each outlet such that an serial control cable may be `passed thru' the panel to facilitate the connection to ground and DTR for the SSR's. An LED is also attached to each DTR line. The ground line is passed thru a relay connected to the chamber control circuit. This relay is controlled via the Power On/Off switch located on the front panel of the chamber. The relay will also be turned off if an Over-temp alarm condition is present in the chamber. This will then disable all SSR's and remove AC power to any product plugged into the 6 UUT Outlets.

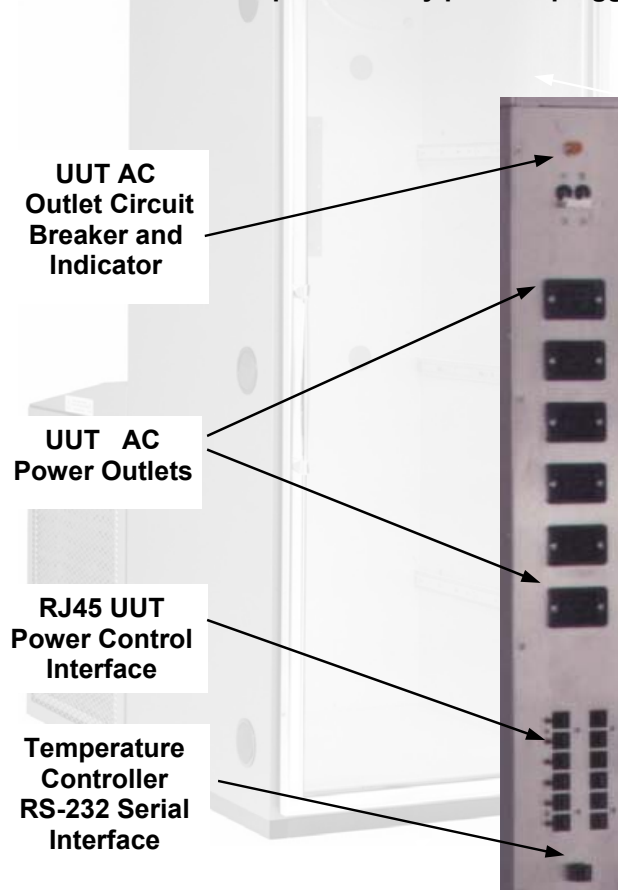

Watlow Controller Quick Operation Guide

RED DISPLAY

This display will normally indicate the current temperature in the chamber. It will also indicate the value of the parameters displayed in the GREEN display.

DISPLAY KEY

This key will cause the GREEN display to step thru displaying the set-point, the deviation from set-point, the % of output power, and whether the temperature is displayed in °C or in °F.

MODE KEY

The 1st press of this key will enter the SYS menu.

Use up arrow key to step to PID menu or PROG menu. See Watlow manual to set PROG values and steps.



UP and DOWN ARROWS

These keys are normally used to change the set-point of the controller. When pressed simultaneously for approx. 3 seconds, you will enter the setup mode. Please see the WATLOW MANUAL.

L1 thru L4 DISPLAY

- L1** - Indicates that the heaters are on.
- L2** - Indicates that the cooling system is on.
- L3** - Dehumidifier Control
- L4** - Indicates that data is flowing over the RS-232 port.

GREEN DISPLAY

This display will normally indicate the current set-point. It will also indicate other functions depending on the use of the DISPY key and the MODE key. Values of these other functions are displayed in the RED display.

RUN / HOLD KEY

Pressing this key once will allow you to select which of the 4 Ramp and Soak profiles to run. The RUN Led will flash at this time. Pressing the key again will start the selected profile. The RUN Led will be on steady while a profile is running. If a profile is running, pressing this key will stop execution of that profile and the RUN Led will be off.

SECTION 3 INSTALLATION

SITE SELECTION:

- Environmental Operating Conditions
Ambient Temperature should be between 6.1°C (43°F) and 29°C (85°F).
Relative Humidity should be no greater than 50%.
- Flooring should be smooth and level
- Minimum clearance for the sides and back of the chamber shall be no less than .91 meters, (three feet).

ELECTRICAL CONNECTIONS:

- 208VAC—230 VAC, 50Hz/60Hz,
Three phase, 60 Amps



Take proper precautions when working with electrical devices.

WARNING! ELECTRICAL SHOCK HAZARD!

POWER CONNECTION CONFIGURATIONS,

- Plug, 4 Pole, Wire Grounding—Hubbell Type Plug—Cybortronics P/N 419004
- Mating Connector—Hubbell Type Connector—Cybortronics P/N 405004
-

CHAMBER EXTERIOR DIMENSIONS:

- Width— 762 mm, (30 inches)
- Depth—1,422 mm, (56 inches)
- Height—2,133 mm, (84 inches)
- Weight—340 Kg, (750 Lbs.)

SECTION 4 SET-UP, OPERATION AND VERIFICATIONS

1. Set-Up:

- Inspect the chamber for shipping damage that may have occurred during transit.
- Inspect that the filters are in place and that there are not any puncture holes.
- Verify that the main breaker located on the back of the Chamber is in the “OFF” position.

- Connect the power cord.



Take proper precautions when working with electrical devices.
WARNING! ELECTRICAL SHOCK HAZARD



The Refrigeration compressor is direction critical. Correct phasing **IS REQUIRED.**

- The wiring of the power supply drop must match the phasing of the chamber wiring.
- Wiring of the chamber is as follows: (from the large ground pin moving counter-clockwise, looking at the plug)
 Large Pin= ground
 L1, L2, L3, Neutral, (moving counter-clockwise)
- Observe the Phase Monitor Status LED located on the Control Panel when the circuit breaker on the chamber is switched on. If the red LED is lit, then the power supply phasing to the chamber is **NOT CORRECT** and must be corrected **BEFORE** the chamber can function.
 - To correct the phasing, at least two of the legs, have to be interchanged.



MAKE SURE THAT THE CHAMBER IS SWITCHED OFF BEFORE UN-PLUGGING THE CHAMBER.

At NO TIME should an attempt be made to change the wiring on the chamber. Damage to the chamber could result and will void the warranty.

- Verify that the power cord for the Dehumidifier is plugged into its designated socket located to the left of the dehumidifier.
- Verify that the red vent plug on the dehumidifier is not blocked or occluded.

2. Initial Start-Up:

NOTE: Your Cybortronics Chamber has been extensively tested at Cybortronics before it was packaged and shipped your location. It is advisable to cycle your chamber to verify all heating and cooling functions are operating properly, before you load the chamber with your product.

At anytime during this verification procedure your chamber does not function as prescribed in this procedure, call Cybortronics Inc. (1-800-289-8203) and ask to speak with a technical service representative.

(When contacting Cybortronics with any service or technical inquiries, please have your chamber model and serial number available)

3. VERIFICATION OF TEMPERATURE CONTROLLER, REFRIGERATION AND HEATER OPERATION

- When the circuit breaker is switched to the “ON” position, the chamber blower will activate and will start to heat or cool the chamber to the temperature set-point on the process controller, (usually 25°C).
- Verify that the chamber will cycle by following the following directions to cycle the chamber to 70°C and down to –10°C.
 1. Press the “↑” arrow keypad while watching the green display and Ramp the temperature up to 70°. The chamber will now activate the heaters and start heating. The red display indicates the actual chamber temperature.
 2. The chamber should take approximately 5 minutes to reach 70°.
 3. At 35°, the Munters Dehumidifier will start. Verify the operation of the dehumidifier by placing your hand over the red capped exhaust port. A warm airflow should be exiting from the port.
 4. Now press the “↓” arrow keypad and reduce the temperature setpoint to –10°, (observing the green display). The chamber will now shut off the heaters. The refrigeration unit will now start and the temperature in the chamber will start to drop.
 5. When the chamber has reached –1°, (the red display), the Munters dehumidifier should shut off. Place your hand in front of the red exhaust port and you should feel the air flow decreasing to nothing as the blower winds down, (this may take several seconds for the blower to stop completely).
 6. Once the chamber has reached –10°, you may reset the chamber set-point temperature to 25°C, (room temp.) or shut the chamber off.
 7. If all of the above functions operate properly, your chamber is now ready to use.

SECTION 5 CALIBRATION:

1. The Watlow Series 998 Controller is the only device on the Model 2050 Chamber that requires calibration. The Time Delay and the Over-Temperature Switch are adjusted at the factory.
 - a. Cybortronics recommends an annual verification of the Watlow Controller. Specific Instructions on how to verify the Watlow Controller can be found on the Watlow Website at: www.watlow.com. Look for the calibration instructions for the 98X Series Controllers. It has been stated by Watlow that the calibration procedures are identical for the 98X series and the 998 Series Controllers.
2. The Watlow Over Temperature Limit has been set at the factory to alarm at 80°C, ± 2°C, (the safe maximum temperature). If the alarm sounds at a different temperature, contact Cybortronics.
3. The Time Delay Switch for the refrigeration unit is programmed to shut off the refrigeration compressor five, (5) minutes after the heating cycle has started. If the switch seems to be malfunctioning or tripping at a different time setting, that a replacement be ordered from Cybortronics Inc.

SECTION 5 MAINTENANCE:

- The HR2050 Temperature Chamber has been designed to provide years of trouble free operation when periodic maintenance schedules are followed. Adhering to the following periodic maintenance schedule will also keep your chamber within warranty.

Maintenance Schedule

Maintenance Activity	Description	Monthly	Semi-Annual	Annual
Condenser Filter (s)	P/N 809002	X		
Restock any spare fuses	Spare holders under the front electrical hood		X	
Check for Clean Condenser	Brush or vacuum as necessary		X	
Condenser Fan Operation	Check all fans for proper operation and direction Condenser Fan, Heater Fan=counterclockwise (viewing rear of mtrs.)	X		
Dehumidifier Filters (2)	Inspect monthly and replace as necessary P/N 809001	X		
Dehumidifier Blower Operation	Check that the dehumidifier is working when the L3 Watlow lamp is OFF. The dehumidifier operates between -1C and +35C. Verify exhaust exiting from red exhaust port	X		
Dessicant Wheel Movement	Look inside exhaust port to see dessicant wheel moving slowly	X		
Check Condensate Hose + Pan	Check condensate pan and hose for good drainage Leave water in copper tube trap to prevent moisture re-entering chamber	X		
Check for Clean Evaporator	Brush or vacuum as necessary		X	
Chamber/Condenser Blower Operation	Good blower air flow/ quiet motor/no vibration		X	
Blower and Condenser Motors	Moving freely, no lubrication required		X	
Check Electrical Connections	Look for discolored lugs, fuses, or relays, under hood		X	
Check Heating Ramp	Ramp the chamber to 60C (dependent on UUT mass) (10-12min)/HR2050	X		

Maintenance Schedule

Maintenance Activity	Description	Monthly	Semi-Annual	Annual
Heater Relay and Element Operation	Check heater current while ramping. L1 lamp should be 'on' solid. Approx. 30 Amps under load @ contact #2 of SSRs (3 of them)		X	
Overtemp Alarm	Dial down overtemp to hear alarm, return to position and reset @ 80 C		X	
Blower Alarm	Inside, back wall, in discharge. Gently push switch up, listen for alarm. Then reset on front panel		X	
Measure Input Voltages	230 Volts, MAX. 3 Phase, check at control panel under hood at L1, L2, L3		X	
Check Refrigeration Operation	Inspect Refrigeration, check for leaks, Check run current, 6.5 Amps		X	
Performance 60-0 C	HR2050=10min ±2 minutes			
Check Compressor Oil Level	Check oil sight glass in compressor for proper level.	X		
Temperature Control Verification	Verify correct reading by sampling at the chambers thermocouple location, inside and just above door jamb. +/-2 degrees C			X

SECTION 7

RECOMMENDED SPARE/REPLACEMENT PARTS

Cybortronics has included in this manual a comprehensive replacement and spare parts list. Refer to your maintenance schedule in this manual for replacement frequency.

Items marked by an asterisk indicate that the replacement and spare parts should be added to your current inventory to reduce downtime.

Contact Cybortronics Inc. at: 1-949-855-2814. A Customer Service Representative will process your order. All orders are shipped F.O.B., Irvine California, USA.

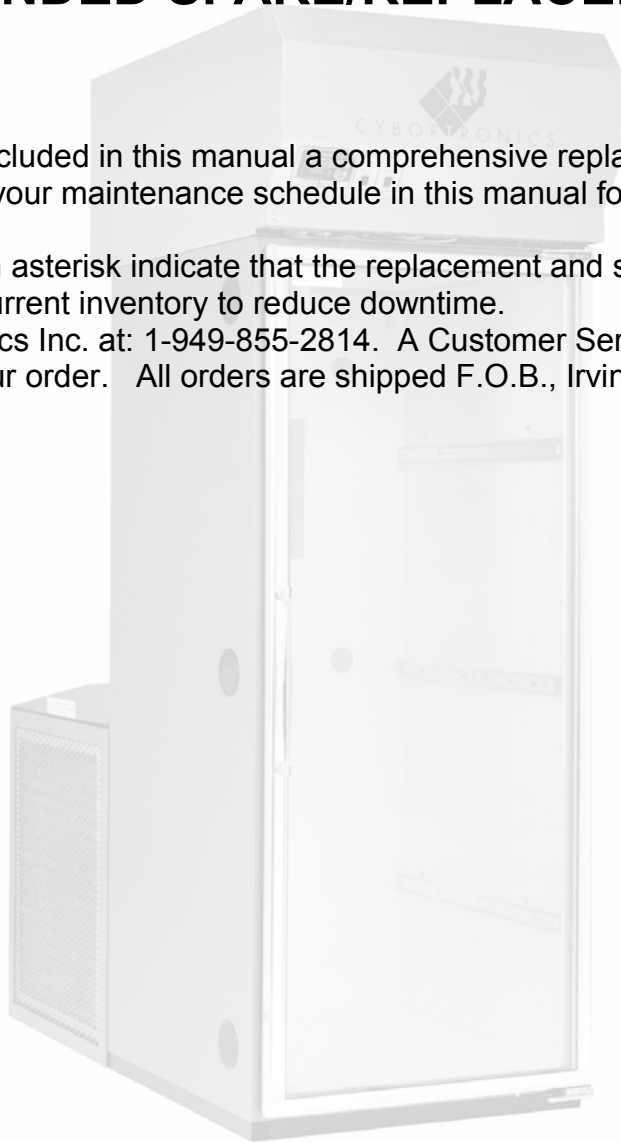

CHAMBER MODEL HR2050 REPLACEMENT PARTS MATRIX

** Recommended on Hand

Description	Location	Part Number
Blower Motor	Top Air Box	412001
Blower Sub-Assembly	Top Air Box	204003
Capacitor, Blower Motor	Top Air Box	411001
Cooling Fan, Blower Motor	Top Air Box	608001
Fan, Condenser	Lower Refrigeration Area	419001
Dehumidifier Control Relay	Main Electrical Panel	402001
Heater Assembly	Top Air Box	204004
Fuse, 5 Amp	Main Electrical Panel	407001*
Fuse, 8 Amp	Main Electrical Panel	407002*
Fuse, 10 Amp	Main Electrical Panel	407003*
Fuse 15 Amp	Main Electrical Panel	407004*
Fuse 15 Amp	Main Electrical Panel	407005*
Fuse 25 Amp	Main Electrical Panel	407006*
Fuse 30 Amp	Main Electrical Panel	407007*
Fuse 40 Amp	Main Electrical Panel	407008*
Solid State Relay, 25Amp	Main Electrical Panel	507003*
Solid State Relay, 75A	Main Electrical Panel	507002*
Solid State Off Delay Timer	Main Electrical Panel	513001
Process Controller	Front Control Panel	418001*
Overtemp Controller	Front Control Panel	418002*
Power Supply, 12V	Main Electrical Panel	202001
Line Phase Monitor	Main Electrical Panel	419002
Fan Switch Assembly	Inside Chamber on Back Wall	204001
Fan Speed Control Unit	Refrigeration Control Box	416001
Main Circuit Breaker 60 Amp	Back Upper Panel	410001*
Dehumidifier Unit	Back of Chamber	204002
Relay, Main Control Board	PCB, Front Control Panel	402004
Refrigeration Contactor	Refrigeration Control Box	606001*
Dehumidifier Filter	Dehumidifier	809001*
Air Filters (12 per case)	Around Refrigeration System	809002*
Low Pressure Limit Switch (5/20)	Lower Refrigeration Area	606002



CHAMBER MODEL HR2050 REPLACEMENT PARTS MATRIX, CONT.

Dehumidifier Filter	Dehumidifier	809001*
Air Filters (12 per case)	Around Refrigeration System	809002*
Low Pressure Limit Switch (5/20)	Lower Refrigeration Area	606002
High Pressure Limit Switch (425/500)	Lower Refrigeration Area	606003
Solenoid Valve	Lower Refrigeration Area	607001
TXV Orifice Cartridge (for Main Expansion Valve Kit)	Lower Refrigeration Area	608004
Main TXV Body (for Main Expansion Valve Kit)	Lower Refrigeration Area	207001
Dryer/Filter	Lower Refrigeration Area	608002
Compressor	Lower Refrigeration Area	604002
Refrigerant	Refrigeration System	608005
UUT Panel		
Outlet Control Relay	Main Electrical Panel	507003*
Revised 12/11//03		

SECTION 8

Drawings and Schematics

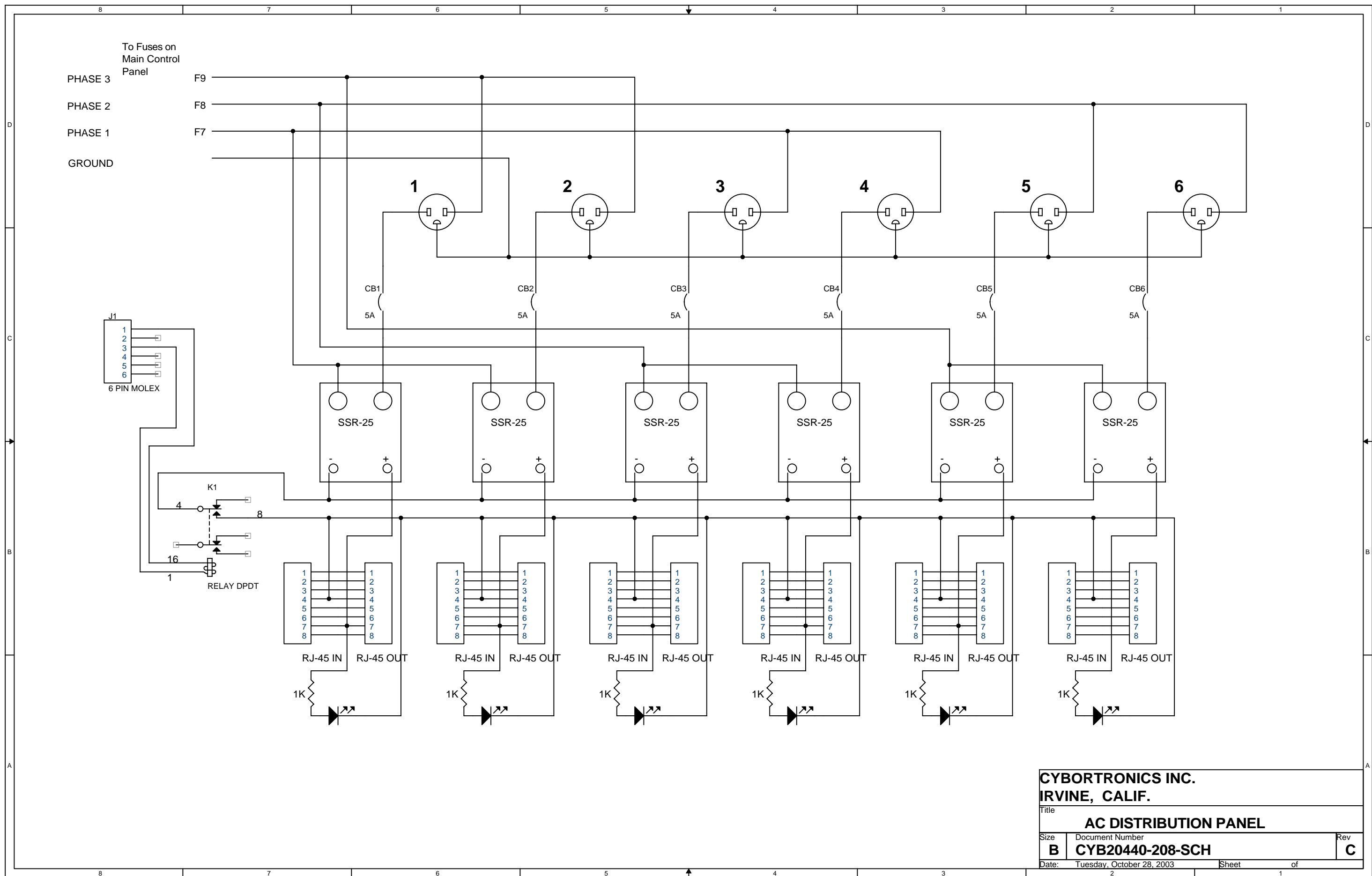

CYBORTRONICS INC.
IRVINE, CALIF.

Title: **AC DISTRIBUTION PANEL**

Size: B	Document Number: CYB20440-208-SCH	Rev: C
Date: Tuesday, October 28, 2003		Sheet 2 of 1

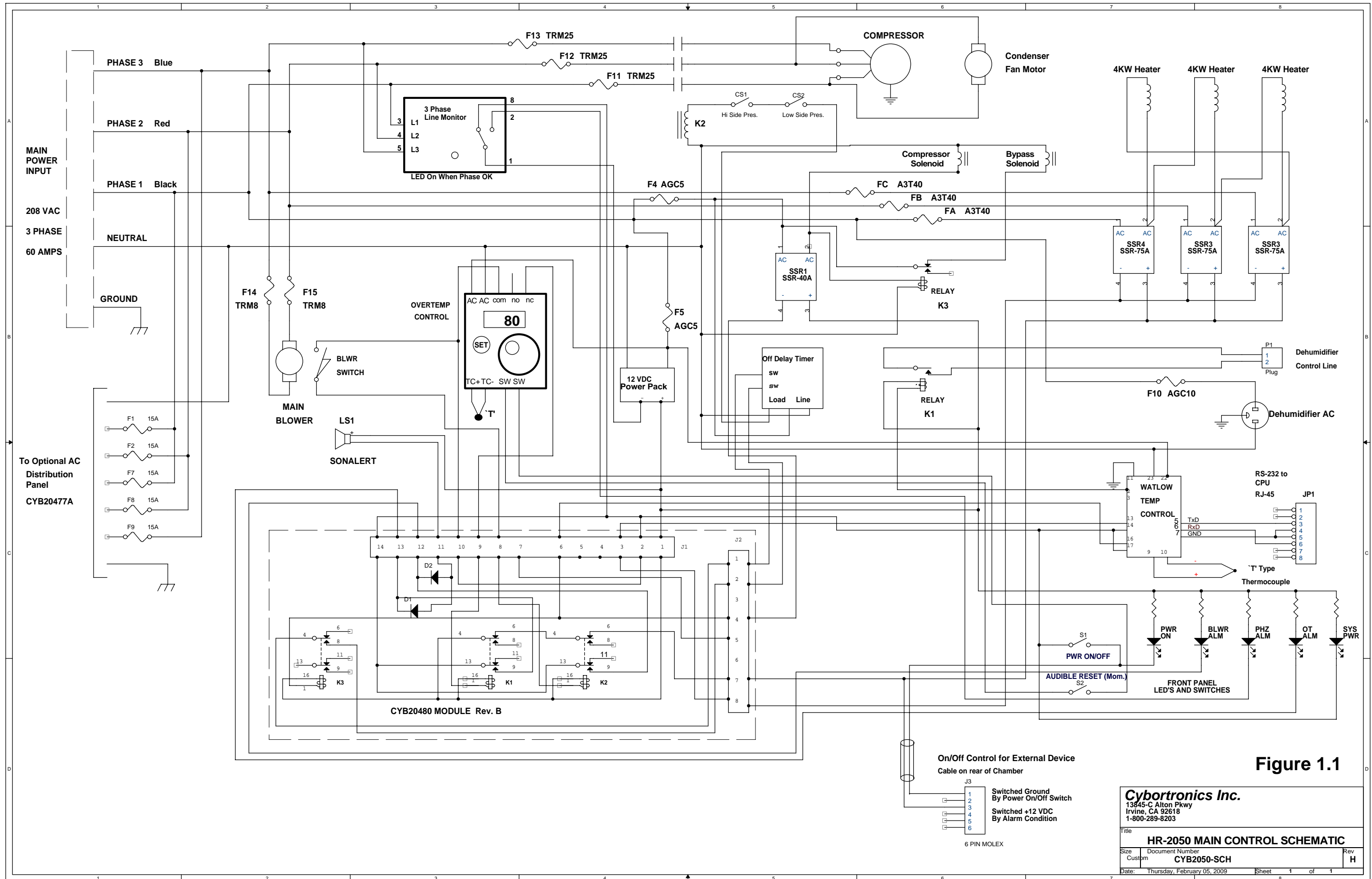

Figure 1.1

Cybortronics Inc.
 13845-C Alton Pkwy
 Irvine, CA 92618
 1-800-289-8203

Title: **HR-2050 MAIN CONTROL SCHEMATIC**

Size	Document Number	Rev
Custom	CYB2050-SCH	H

Date: Thursday, February 05, 2009 Sheet 1 of 1

R-507 Refrigerant

HR2050

- Genetron AZ-50
 Pentafluoroethane -50%
 1. 1.1 Trifluoroethane -50%
 2. 2. UN3163

Ambient Operating Temp. 68-75 F
 Standard Charge: 6.5 lbs @ 68-75 F

In Box Temp Pulldown From 70°C to -10°C:
 Liquid Side High Pres NTE 350 psig
 Suction Side Pres NTE 120 psig
 At -10°C Box Temp: Suction Pres = 30 psig
 By-pass Mode Suction Pressure = 10-30 psig
 By-pass Mode Suction Temp = 37.5° F nom.

ACCU - ACCUMULATOR
COMP - COMPRESSOR
COND - CONDENSER
EVAP - EVAPORATOR
FLT - FILTER
GV - GLOBE VALVE
HPCO - HIGH PRESSURE CUT OUT
LPCO - LOW PRESSURE CUT OUT
REC - RECEIVER
SG - SIGHT GLASS
MSV - MAIN SOLENOID VALVE
MTXV - MAIN THERMOSTATIC EXPANSION VALVE
BSV - BYPASS SOLENOID VALVE
BTXV - BYPASS THERMOSTATIC EXPANSION VALVE

